

Indicator with Microprocessor

5-digit LED-display

with two-coloured display

and two limit contacts



Description

Indicators are electronic devices designed for digital display of sensor signals. They also supply the sensor with the power required and, with aid of additional facilities such as limit contacts and analog output, provide information on the status of the process being monitored.

The indicators can be set to the desired measuring range on site by program-control. If necessary a non-linear scaling with up to 10 scaling respectively indicating point is provided. If required an offset is adjustable. Both the input signal and the analogue output (option) are freely selectable.

The programming is carried out with the function keys on the front of the device. To analyse varying measuring signals a peak value memory (MIN/MAX) and a filter function are available.

For data transmission to a PC a digital interface can be obtained. As an alternative a digital input to control the unit can be provided.

The indicator possesses a two-coloured display. The desired colour for operation or alarm can be selected.

Features

- freely programmable by microprocessor
- scale setting on site, without external calibration equipment
- integrated sensor supply
- display colour freely selectable for operation and alarm mode
- freely selectable input signal
- two limit contacts:
freely programmable contact function
- filter function
- peak value memory (MIN and MAX)
- option: analogue output freely selectable
- option: digital interface RS485
- option: digital input

Applications

chemical and petrochemical industry,
pharmaceutical industry,
food and beverage,
machine tools and injection moulding,
presses,
development and testing.

Model: 1926.300 , 1926.300

Technical data

Model	1926.300	1929.300
Display	2-coloured 7-segment-LED-display	
– colours	red and green: basic colour and alarm colour programmable	
– height	18.5 mm	
– range	-19999...99999 (5 digits)	
– accuracy	0.03% of F.S. ± 1 digit	0.01% of F.S. ± 1 digit
– conversion rate	10/sec.	
Measuring range	free scaling by using up to 10 scaling points	
Input	0...100 mV	selectable: 4...20 mA 0...10 VDC 0...20 mA 0...5 VDC ± 10 VDC
– channels	1	
– input resistance	for current input: 10 Ω for voltage input: 950 kΩ	
– temperature influence	≤ 0.25% of F.S./10K	
Sensor supply	selectable: 5 VDC / 10 VDC; max. 125 mA	24 VDC; max. 30 mA
Display functions	peak value memory (MAX and MIN)	
– memory	programmable up to 100s	
– filter function	freely programmable -19999...99999	
– process offset		
2 limit switches	2 transistor outputs: 30 VDC / 100 mA; n-switching 1 relais (changeover contact): 240 VAC / 3A or 110 VAC / 5 A <i>transistor output 1 and relais output 1 are combined</i> limit switch as Hi or Low programmable	
– function	program controlled adjustable over the whole display range	
– switching point	1 display digit	
– hysteresis	transistor output: < 75µs	
– response time	relais output : ca. 8 ms	
Mains supply	90...264 VAC 50/60 Hz (galvanically separated of all in- and outputs)	
– power consumption	< 4 Watt	
electrical connection	screw terminals on the case	
temperature ranges	0...55 °C	
– operation	-20...60 °C	
– storage	0...90%, non condensating	
– relative humidity		
Protection type	front panel IP66	
Case	dimensions see drawings	
– material	GE Lexan 940	
– mounting	panel mounting with clamping frame	
Weight	approx. 0.25 kg	

Options

Model	1926.300	1929.300
Mains supply	20...50 VAC respectively 22...55 VDC	
Relais output 2	1 relais changeover contact: 240 VAC / 3A or 110 VAC / 5 A <i>transistor output 2 and relais output 2 are combined</i>	
Analogue output	selectable: 4...20 mA, 0...10 VDC 0...20 mA 0...5 VDC	
- resolution	8 Bit in 250 ms	
- accuracy	± 0.25% of. F.S., (linear deviation: ± 0.5% of F.S.)	
- load resistor	for current output: max. 500 Ω for voltage output: min. 500 Ω	
interface ¹⁾	9600...1200 baud, 1 start bit, 7 data bits, 1 stop bit, even parity	
- RS 485	n-switching - High ≥ 3 V, Low ≤ 2 V; TTL-capable; response time 25 ms	
- digital input		

of. F.S. = of full scale¹⁾

Option: interface only one at a time.

Operating and connection elements

Front view

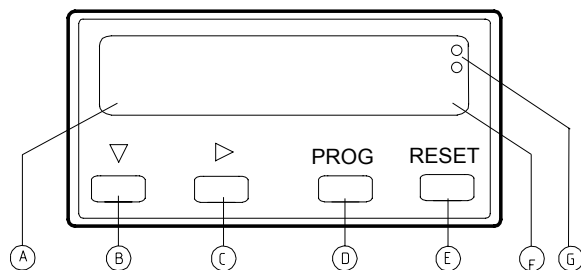

- A LED-display
- B function key downward counting
- C function key scroll
- D function key programming mode
- E function key reset
- F secondary display
- G status indication output 1 and 2

Back view

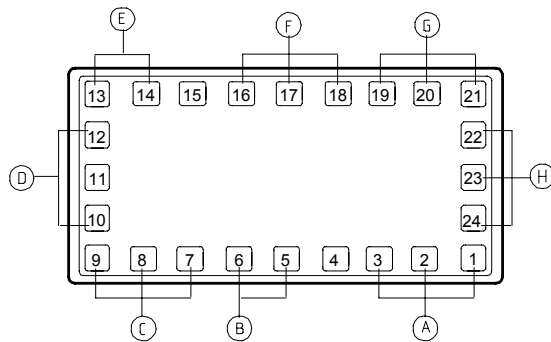

- A input signal
- B sensor supply
- C transistor output
- D analogue output
- E mains supply
- F interface
- G relais output 1
- H relais output 2

Dimensions (mm)

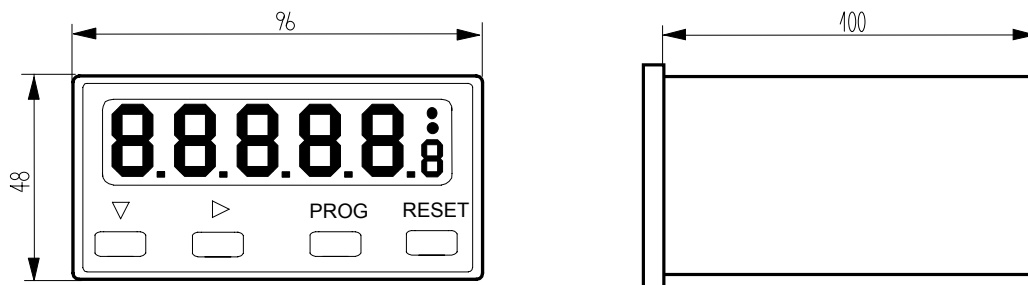

sectional view of switchboard: 45^{+0.3} mm x 92^{+0.3} mm, panel max. 12mm

Configuration of connection terminals

Connection terminal

	1926.300	1929.300
1	input -	
2	input +	input + V
3	sensor supply -	input + mV, mA
4	sensor supply +	free
5	sensor supply -	
6	sensor supply +	
7	transistor output 1	
8	transistor output 0V	
9	transistor output 2	
10	analogue output -	
12	analogue output +	
13	mains supply +	
14	mains supply -	
16	digital input B	
17	digital input A	
18	digital input 0 V (only for RS 485)	

Relais output 1



Relais output 2



Connection examples

Signal input

Two-wire 4...20 mA

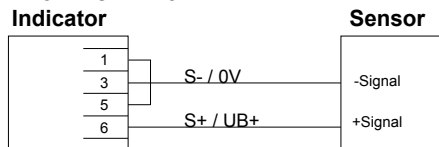

Three-wire 0...20 mA

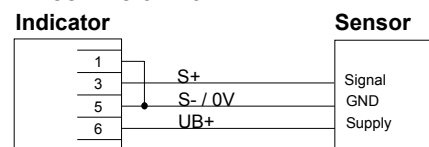

Three-wire 0...10V

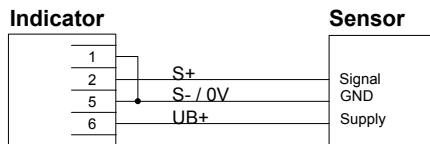

Four-wire 0...10V

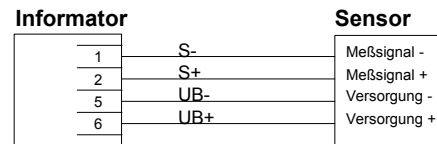

Four-wire 0...100mV

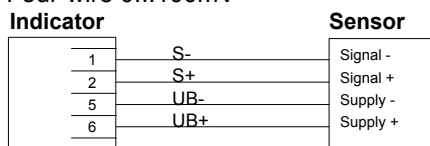

Six-wire 0...100mV

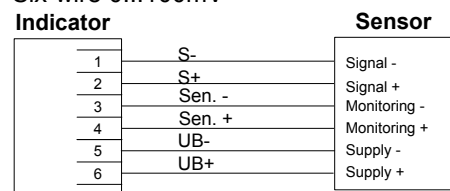

Analogue output

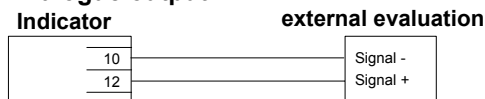

Order details

1. Model
2. Options